

## ★ Perfect Solution For Auto Power Controlled Laser Diode

### ● Features

1. 3.3mm package and 650nm 7mW 70°C operation
2. Low operation current
3. Saving space and cost of laser module
4. Voltage driven LD, easy to use

### ● Outline Dimension

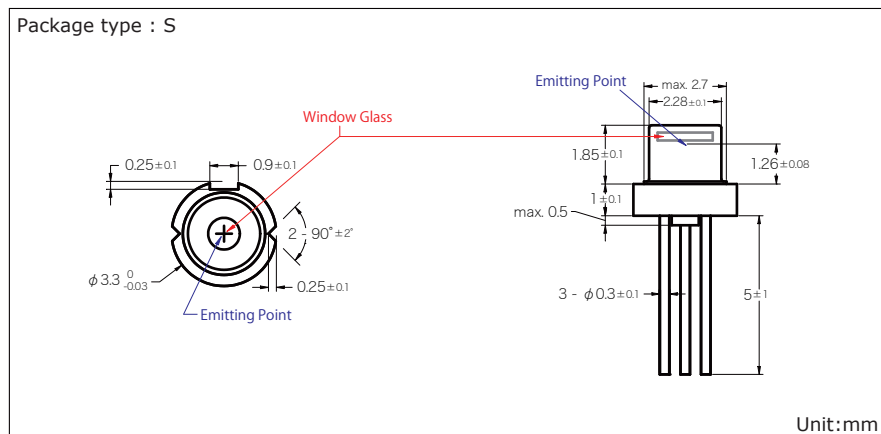

Fig.1: Outside view

### ● Block Diagram

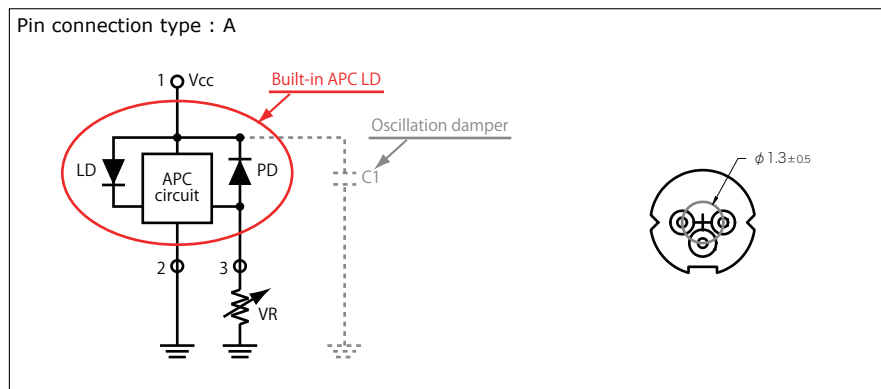

Fig.2: Pin connection

1. Traditional LD needs to connect an external APC circuit board for the constant power operation. The VR(variable resistor) is used to adjust the laser output to a desired target power.
2. LD650-7-SA consists an APC IC inside the **To-3.3mm** package, and leaves the VR outside for adjusting the optical output power.
3. Oscillation Damper is recommended for stabilizing the optical output power.

### ● Maximum Ratings:

Item	Symbol	Rating	Unit
Power supply voltage	V <sub>cc</sub>	2.5-6.0*	V
Laser optical output power	P <sub>o</sub>	10	mW
Operation temperature	T <sub>opr</sub>	-10~+70	°C
Storage temperature	T <sub>stg</sub>	-40~+85	°C

\* Effective heat sink is recommended on 6V case due to extra heat.

### ● LD650-7-SA Electrical-Optical Characteristics @T<sub>c</sub>=25°C:

Item	Symbol	Min.	Typ.	Max.	Unit	Conditions
Wavelength	λ	645	650	660	nm	P <sub>o</sub> =7mW
Operation current	I <sub>op</sub>	-	25	35	mA	P <sub>o</sub> =7mW
Variable resistor	VR	1	3.5	7	kΩ	V <sub>cc</sub> =3V
Parallel divergence angle	θ <sub>//</sub>	6	9	12	deg	P <sub>o</sub> =7mW
Perpendicular divergence angle	θ <sub>⊥</sub>	25	30	32	deg	
Parallel FFP deviation angle	Δθ <sub>//</sub>	-3.0	0	+3.0	deg	
Perpendicular FFP deviation angle	Δθ <sub>⊥</sub>	-3.0	0	+3.0	deg	
Emission point accuracy	ΔxΔyΔz	-80	0	+80	μm	
Power-Temp stability (25~70°C)	ΔP <sub>OT</sub>	-20	-10	0	%	P <sub>o</sub> =7mW, V <sub>cc</sub> =3V
Power-Vcc stability (6.0~3.0V)	ΔP <sub>ov</sub>	-15	-10	0	%	P <sub>o</sub> =7mW, Temp=25°C
Power-Vcc stability (3.0~2.5V)	ΔP <sub>ov</sub>	-15	-10	0	%	P <sub>o</sub> =7mW, Temp=25°C

### ● Laser Safety Precautions

1. To protect laser from overdriving condition, setting VR to maximum value before you turn on Vcc can minimized the laser output power.
2. Do not operate the device above the maximum rating condition, even momentarily. It may cause unexpected permanent damage to the device.
3. Semiconductor laser device is very sensitive to electrostatic discharge. High voltage spike current may change the characteristics of the device, or malfunction at any time during its service period. Therefore, proper measures for preventing electrostatic discharge are strongly recommended.
4. To obtain a stable characteristic and good reliability, the effective heat sink is necessary. So it is recommended that always apply proper heat sink before the device is operating.
5. Do not look into the laser beam directly by bare eyes. The laser beam may cause severe damage to human eyes.